

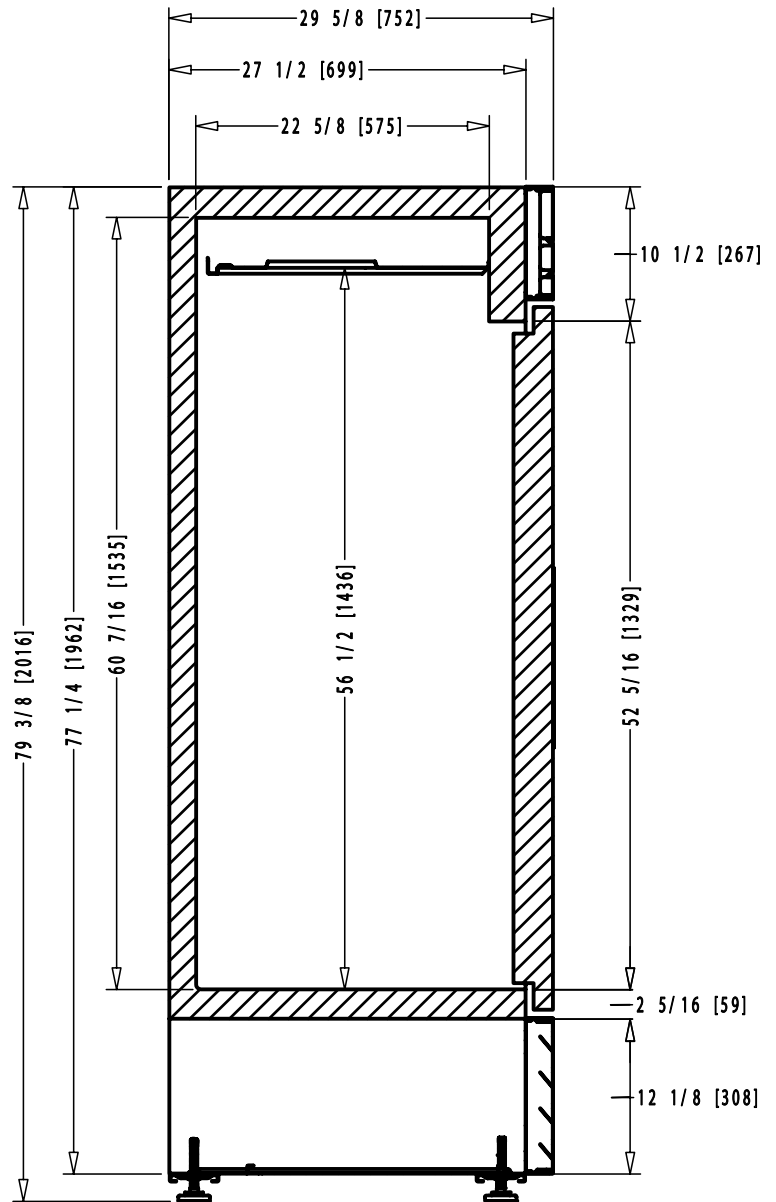

Side view / Vista lateral:

In [mm] / Pulg. [mm]:



Top view / Vista superior:

In [mm] / Pulg. [mm]:

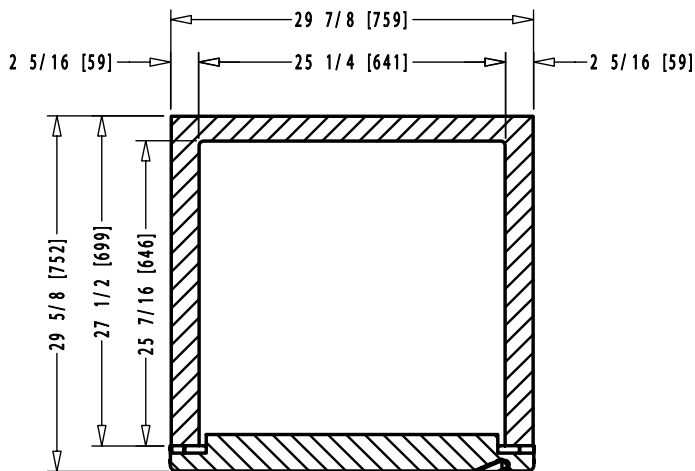

FEATURES / CARACTERÍSTICAS:

- Forced-air technology with automatic defrost. / Tecnología de aire forzado con deshielo automático.
- Electronic temperature control. / Control electrónico de temperatura.
- Solid door for improved insulation. / Puerta sólida para mayor aislamiento.
- LED interior illumination. / Iluminación interior LED.
- Stabilizer heels / Tacones estabilizadores.
- Low maintenance condenser / Condensador de bajo mantenimiento.
- CFC-free polyurethane insulation with cyclopentane as the blowing agent / Aislante de poliuretano, libre de CFCs, con ciclopentano como agente espumante.

DIMENSIONS DIMENSIONES			CAPACITY* CAPACIDAD*		SHIPPING ENVÍO	TECHNICAL INFORMATION INFORMACIÓN TÉCNICA					
in / pulg mm											
Height Alto	Width Frente	Depth Fondo	Cubic ft / Lt. Pies3 / lts.	Shelves Parrillas	40' / 45' - container Contenedor de 40' / 45'	Temperature* Temperatura*	HP	Amps Amperaje	Refrigerant Refrigerante	Voltage Voltaje	Doors Puertas
79 3/8 2,016	29 7/8 759	29 5/8 752	24 / 680	4	45 / 51	-9°F - 0°F -23°C - -18°C	1/2	4.5	R 290	115V/60Hz/1	1